

## RESERVE BOOTH SPACE

### EXHIBIT HALL SCHEDULE

#### EXHIBITOR MOVE-IN

**April 20:** 8:00am – 5:00pm

**April 21:** 8:00am – 10:00am

#### SHOW HOURS

**April 21:** 10:30am – 4:00pm

**April 22:** 10:30am – 3:30pm

#### EXHIBITOR MOVE-OUT

**April 22:** 3:30pm – 7:00pm

*Dates & Hours are subject to change*

*\* General Liability Insurance – required for all companies located outside of the United States and Canada.*

### BOOTH FEES

- Linear Booth: \$55.50 per sq. ft.
- Island Booth: \$61 per sq. ft.
- Each Corner Premium: \$300
- General Liability Insurance: \$185 flat fee\*

### BOOTH FEES INCLUDE:

- Booth Space
- Draped back wall and 3' draped side rails (Linear booth only)
- 7" x 44" ID Sign (Linear Booth only)
- Company listing on the show website, mobile app, Expo Preview and Show Guide
- Four Exhibitor badges per 100 sq. ft.

### TABLETOP FEES

- Tabletop: \$3,275
- General Liability Insurance: \$185 flat fee\*

### TABLETOP FEES INCLUDE:

- (1) Draped counter height table 4"W x 24"D x 42"H
- (2) Counter height chairs
- (1) 7" x 44" ID sign
- (1) wastebasket
- Facility is carpeted (No additional flooring is permitted)
- Two Exhibitor badges
- Company listing in mobile app, Show Guide and SupplySide Connect for a basic 12-month listing.

### WHO EXHIBITS?

- Ingredient suppliers
- Contract manufacturers
- Equipment and machinery companies
- Flavor and fragrance suppliers
- Packaging and labeling suppliers
- Lab testing and analytical labs
- Wholesalers, distributors and brokers
- Service providers
- Legal/regulatory
- Clinical research
- Product development

### WHO ATTENDS?

3,000+ CPG decision-makers representing 36 countries in the key industries of nutrition, health and food.

### READY TO RESERVE YOUR SPACE?

To reserve your booth, inquire about Sponsorship Opportunities and to learn about SupplySide Connect, **contact your Account Manager or Danica Cullins at (480) 281-6713 or [danica.cullins@informa.com](mailto:danica.cullins@informa.com).**

## BOOTH PACKAGES

Having a presence on the SupplySide East show floor is even easier and affordable.

### PACKAGE A \$8,700



- 100 sq. ft. In-line booth space
- Back wall with custom graphics\*
- Counter with custom graphic kick panel & locking doors\*

- (1) Starbase Table 36"W x 30"H
- (2) Padded Chairs
- (1) Padded Stool
- (1) Wastebasket
- Carpet (7 color choices)

- Electricity
- Booth vacuuming
- Exhibit install and dismantle
- Material handling of rented exhibit structure, delivery to and from show site
- 4 Exhibitor badges

### PACKAGE B \$9,700



- 100 sq. ft. In-line booth space
- Back wall structure – solid inset wall panels
- (1) Graphic Header\*
- (1) Center Wall Graphic\*
- (6) Shelves
- (1) Padded Stool

- (1) Wastebasket
- Welcome counter with graphics & locking doors\*
- Carpet (7 color choices)
- (1) Arm light
- (2) Tracks with (4) lights
- Electricity

- Booth vacuuming
- Exhibit install and dismantle
- Material handling of rented exhibit structure, delivery to and from show site
- 4 Exhibitor badges

### PACKAGE C \$17,300



- 200 sq. ft. In-line booth space
- Curved graphic back wall structure with (3) shelves\*
- (4) Padded Chairs
- (1) Starbase Table 36"W x 30"H

- (1) Wastebasket
- Welcome counter with graphics & locking doors\*
- Carpet (7 color choices)
- (5) Arm lights
- Electricity

- Booth vacuuming
- Exhibit install and dismantle
- Material handling of rented exhibit structure, delivery to and from show site
- 8 exhibitor badges

Corner locations will have an added corner fee. Any additional orders that are not included in the booth package are at the expense of the exhibitor. All nongraphic panels will be white in color. Exhibitor must obtain general liability insurance at own expense.

*\*Client to provide print-ready graphics*

Ready to reserve your space? Contact Danica Cullins at (480) 281-6713 or [danica.cullins@informa.com](mailto:danica.cullins@informa.com)

## INTERNATIONAL BOOTH PACKAGES

Having a presence on the SupplySide East show floor is even easier and affordable.

### PACKAGE A \$8,885

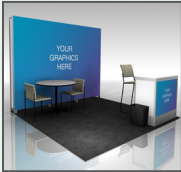

- 100 sq. ft. In-line booth space
- Back wall with custom graphics\*
- Counter with custom graphic kick panel & locking doors\*

- (1) Starbase Table 36"W x 30"H
- (2) Padded Chairs
- (1) Padded Stool
- (1) Wastebasket
- Carpet (7 color choices)
- Electricity

- Booth vacuuming
- Exhibit install and dismantle
- Material handling of rented exhibit structure, delivery to and from show site
- 4 Exhibitor badges
- International Exhibitor Insurance

### PACKAGE B \$9,885



- 100 sq. ft. In-line booth space
- Back wall structure – solid inset wall panels
- (1) Graphic Header\*
- (1) Center Wall Graphic\*
- (6) Shelves
- (1) Padded Stool

- (1) Wastebasket
- Welcome counter with graphics & locking doors\*
- Carpet (7 color choices)
- (1) Arm light
- (2) Tracks with (4) lights
- Electricity

- Booth vacuuming
- Exhibit install and dismantle
- Material handling of rented exhibit structure, delivery to and from show site
- 4 Exhibitor badges
- International Exhibitor Insurance

### PACKAGE C \$17,485



- 200 sq. ft. In-line booth space
- Curved graphic back wall structure with (3) shelves\*
- (4) Padded Chairs
- (1) Starbase Table 36"W x 30"H

- (1) Wastebasket
- Welcome counter with graphics & locking doors\*
- Carpet (7 color choices)
- (5) Arm lights
- Electricity

- Booth vacuuming
- Exhibit install and dismantle
- Material handling of rented exhibit structure, delivery to and from show site
- 8 exhibitor badges
- International Exhibitor Insurance

Corner locations will have an added corner fee. Any additional orders that are not included in the booth package are at the expense of the exhibitor. All nongraphic panels will be white in color. Exhibitor must obtain general liability insurance at own expense.

*\*Client to provide print-ready graphics*

Ready to reserve your space? Contact Danica Cullins at (480) 281-6713 or [danica.cullins@informa.com](mailto:danica.cullins@informa.com)

## Table Top: \$3,275

- (1) Draped counter height table 4'W x 24"D x 42"H
- (2) Counter height chairs
- (1) 7" x 44" ID sign
- (1) wastebasket
- Facility is carpeted (No additional flooring is permitted)
- Two Exhibitor badges
- Company listing in mobile app, Show Guide and SupplySide Connect for a basic 12-month listing.

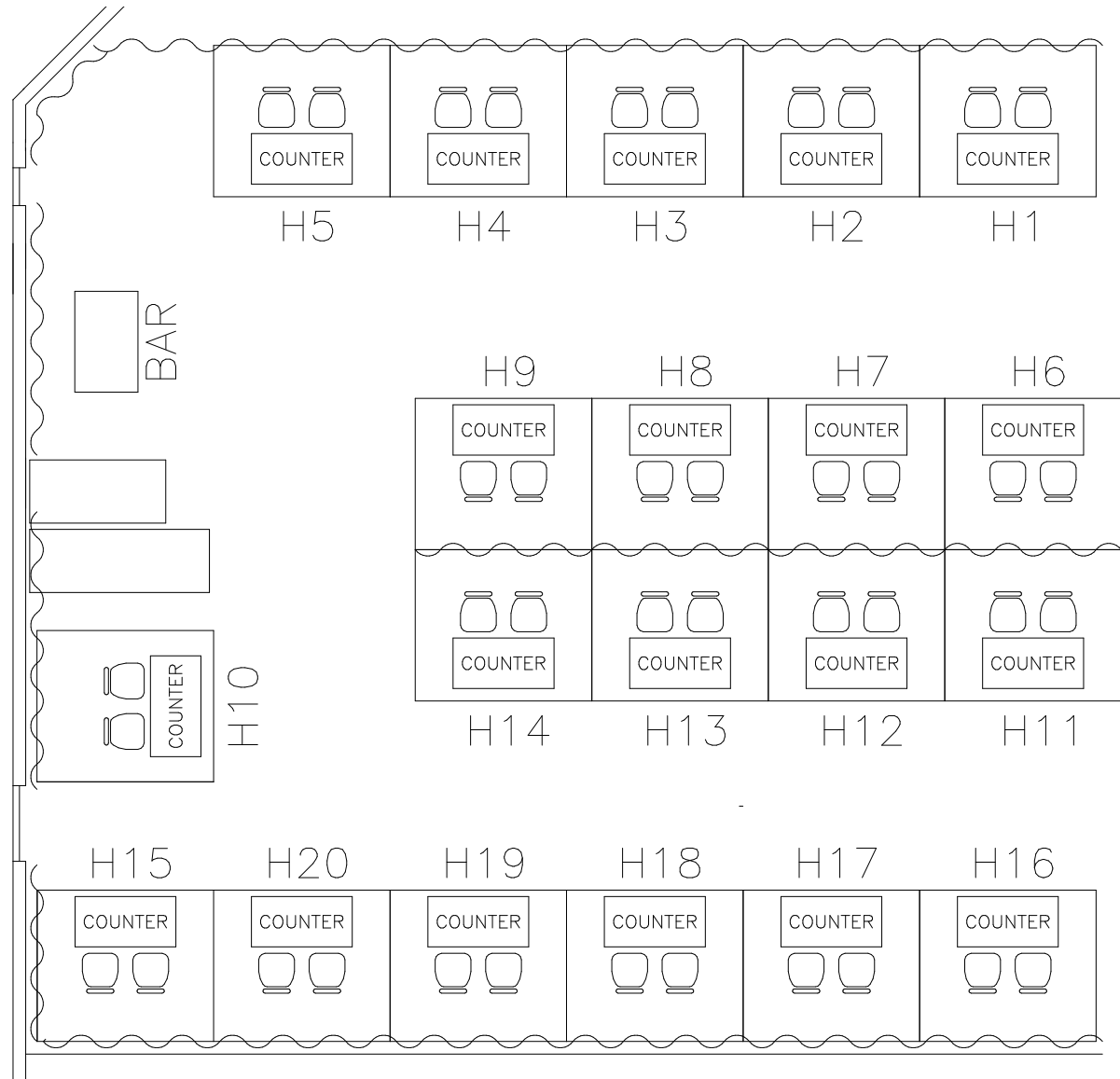

## SUPPLYSIDE EAST 2020 TABLETOP RULES AND REGULATIONS

- Display space is **ONLY the table top area**; the **ONLY storage space is under your tabletop**.
- Any items not stored underneath your table (or displayed on top of the table) will be removed and stored at the exhibitor's expense by SMG. No items will be allowed to be stored or set up surrounding your table.
- Bringing in your own table is **NOT** allowed. Table provided cannot be moved from front of space.
- Display space cannot extend beyond the 4' width x 24" depth tabletop surface. Maximum display height on top of table is 4'.
- Banners and pull-ups displays are only allowed if they are **flat and flush** against the pipe and drape behind your tabletop. Banners must be hung from the pipe and drape. Maximum size is 4ft width and cannot exceed 8ft in height. (bottom 42" will not be seen due to table)
- Exhibitors must also comply with the Show Rules and Regulations in the Exhibitor Service Kit.
- Rules and Regulations are subject to change.

**Note: Exhibitors will be asked to remove any exhibits not in compliance with these guidelines and items will be stored at exhibitor's expense.**

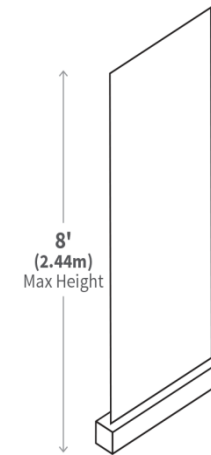
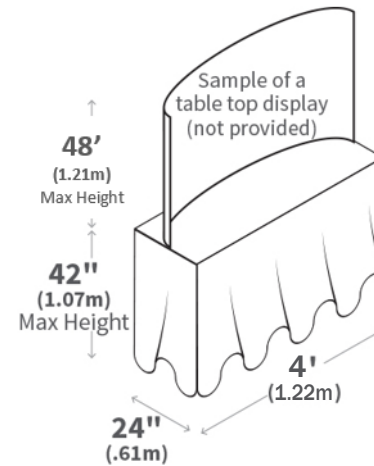

All banners must be flush against drape.

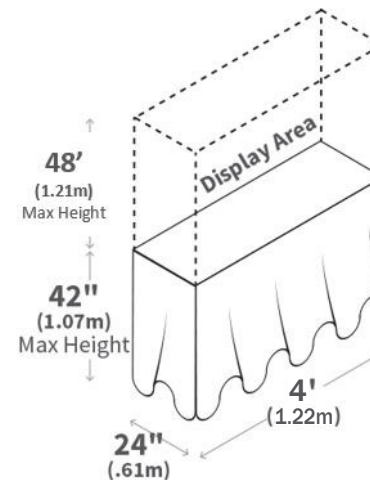

## SUPPLYSIDE EAST 2020 TABLETOP RULES AND REGULATIONS

### Permitted

- YES** Hanging a sign or banner from the back pipe and drape in your exhibit space. Maximum size of sign or banner is limited to 4'W x 8'H (bottom 42" will not be seen due to table).
- YES** May place a branded table cloth over your tabletop. Maximum size permitted is 4'W x 42"H table front dimension and 24"W x 42"H side dimension. (Cannot extend outside of these dimensions)
- YES** Displaying items on the surface of the tabletop. Maximum size permitted is 4'W x 24"D x 3'H (see diagram).
- YES** Flat Pull-Up displays only, must be flush against the pipe and drape behind your table only. Maximum size of pull-up cannot exceed 4'W x 8'H (bottom 42" will not be seen due to table).

### Not Permitted

- NO** Storage allowed behind or around the tabletop area. May only store items that fit under the table. Additional accessible storage space must be purchased from SMG.
- NO** Removing or replacing your table
- NO** Moving tables from front of space or pushing tables together
- NO** Each tabletop space is separate and cannot be combined with another space. (You may not move 2 tables together or utilize the back wall space between the tables)
- NO** Bringing in your own floor covering
- NO** Swapping or adding, tables, other furniture, display counters, refrigerated display cases, etc.
- NO** Refrigerator or freezer behind tabletop. Unit must fit on or under the tabletop.
- NO** Hanging signs (hanging signs rigged from the ceiling)
- NO** Building any structures that surround the table
- NO** Pop-up tents will not be allowed.

Additional questions or clarification should be directed to your Client Services Specialist.  
[https://east.supplysideshow.com/en/Attend/Contact\\_Customer\\_Service.html](https://east.supplysideshow.com/en/Attend/Contact_Customer_Service.html)